

Tie-Down Systems: Critical Code Changes

By Alfred D. Commins

Tie-down systems help buildings resist uplift from wind and seismic forces. Full design performance must include strength, elongation, and shrinkage and must be reliable. The IBC and ICC Evaluation service recently clarified the design procedures for tie-down systems. Clarification is included in the 2009 International Building Code¹; AC 155², Hold-Downs; AC 316³, Shrinkage Compensators; and AC 391⁴ Tie-Down Systems. Unless these changes are explicitly followed, tie-down systems may not perform to code. This paper outlines the changes, shows how to determine system elongation and for illustration purposes, compares three different systems.

Elongation Limits

Tie-down system strength has not been a serious code issue yet system elongation has been a matter of discussion for years. Elongation has been a problem because no clear limit existed and elongation components were not specified. The July, 2010 revision of AC391 has resolved both problems.

AC 391, Tie-Down Systems⁵ specifies elongation limits of 0.180" for rod only and 0.250" for high wind systems. The 0.250" system limit includes bending of double top plates.

Seismic limits are a little different. According to the IBC, shear walls using tie-down systems have elongation limits partly based on the aspect ratio of the shear wall. **IBC**⁶ **Section 2305.3** limits shear wall drift per the following:

$$\Delta_{xe} = \frac{8vh^3}{EAb} + \frac{vh}{Gt} + 0.75he_n + \frac{h}{b}d_a$$

The last component, d_a , is the elongation of the overturning anchorage. Jurisdictions that limit tie-down deflection vary elongation requirements from 0.125" for rod only to system limits of 0.200".⁷ Some engineering companies are using 0.125" as a system limit.

Elongation Components to be Included

AC 391 addressed system elongation to include the total of:

- a. Rod elongation based on net tensile area⁸.
Rod elongation = $\Delta_{rod} = PL/A_nE$, where $A_n = .7854(D-0.9743/n)^2$.⁹
- b. Bearing plate wood crushing assuming bearing deformation of 0.040" at the design compression value with a linear load deformation relationship.¹⁰
- c. The design of tie-downs used in series shall account for the cumulative deformation of all tie-downs within said series.¹¹ Tie-downs that span a floor require the elongation of two tie-downs. For example: the elongation of a single tie-down may be 0.131" at the design load. But elongation across a floor from a pair of tie-downs is 0.262", not including shrinkage.
- d. Shrinkage compensation displacement shall be adjusted at the corresponding load in accordance with AC 316¹².

- e. Shrinkage compensator device movement, Δ_r = average travel and seating increment is independent of load and is added in full. This new section acknowledges moving elements that reverse direction introduce looseness. This looseness can vary from 0.000” (screw devices) up to 0.180” (ratchets.) To understand the effects of Δ_r , click www.comminsmfg.com/video_demo_page_1.htm and watch a 4 minute video on shrinkage compensator looseness.

Table 1 details tie-down system performance including system strength and elongation.

Table 1: Tie-Down Systems: Code References.

	Component	Strength	Elongation		Source	
		Per	Stretch	Per	Acceptance Criteria	Section
1	Rod	AISC 360 or AISI S100	Δ_{rod}	$= P/A_r E$	AC391	S3.2.1.1
Bearing Plate or Tie Down (reaction point)						
2	Bearing Plate	NF&PA NDS2005	$\Delta_{bearing}$	= 0.040"	AC 391	S 3.2.1.2
	Tie-Down	AC 155	$\Delta_{tie-down}$	Tested	AC155	S 6.2.6.3
Shrinkage Compensator						
3	Shrinkage	Shall Be Determined	$\Delta_{shrinkage}$	Calculated	AC391	S6.3.1.3(b)
	Tested Expansion Capacity	AC 316 S6.1	$\Delta_{expansion}$	Tested	AC316	S6.3
	Take-Up Device		$\Delta_{allowable\ load}$	Tested	AC316	S6.5
	Ratchet Increment		$\Delta_r\ avg.\ travel$	Tested	AC316	S6.6
Design Limits		Lowest Strength Component	Elongation Sum		AC391	S3.2.2.2

With components defined, system design is next. Designers first examine rod strength and then evaluate elongation. Elongation components include: rod elongation, tie-down deflection, bearing plate crushing, shrinkage compensator deflection, and ratchet increment. A structured, step-by-step approach insures all items are included. The Table 2 example evaluates all factors.

Design Process: Step-By-Step

Component loading and deflection is reviewed floor by floor. To insure nothing is overlooked a table listing all possible tie-down Items is used. Relevant items are selected as needed. See table 2 example.

1. List all required components. Components include rods, tie-downs, hold-downs, bearing plates, wood shrinkage compensators and wood shrinkage. Wood shrinkage is considered “deflection without load”.

2. Select components for strength and fit compatibility. Designers select predesigned elements from look-up tables. Tables provide strength and deflection (elongation) at allowable load limits. The actual deflection is computed as a function of actual load.

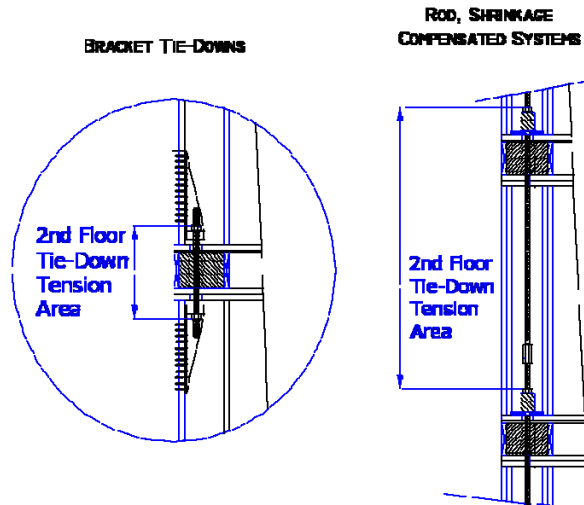

Table 2: Strength and Elongation applied to a Typical System

Item	Strength			Elongation					
	Ref.	Example	Code Reference			Example		Operation/Comment	
	Allowable		Item	Reference	Section	Maximum	Adjusted		
1	Rod	AISC360	13,530	Δ_{rod}	AC391	S3.2.1.1	0.113	0.092	Calculated $\Delta=PL/A,E$
2	Bearing	NDS2005	12,360	$\Delta_{bearing}$	AC391	S3.2.1.2	0.040	0.036	Adj. Demand/Supplied
	Tie-Down	AC155	NA	$\Delta_{tiedown}$	AC155	S6.2.6.3	Not Used		Adj. Demand/Supplied
3	a Shrinkage		1.00	$\Delta_{shrinkage}$	AC391	S6.3.1.3(b)		1.000	Calculated
	b Expansion Cap.		1.10	$\Delta_{expansion}$	AC316	S 6.3	1.100		Capacity Exceeds Demand
c	Take-Up Device	AC316	25,300	$\Delta_{allowable\ load}$	AC316	S 6.5	0.032	0.014	Adj. Demand/Supplied
d	Ratchet Increment	AC316	--	$\Delta_{ratchet\ travel}$	AC316	S 6.6	0.002	0.002	Applied in Full
System Strength			12,360	E_{sum}	AC 391	S3.2.2.2		0.143	Total System Δ
Required Strength			Given						
Required Strength			11,000						
Check	Strength D/C Ratio	89%			Elongation D/C Ratio	80%		Limits Acceptable	

Bearing includes either a bearing plate calculated per NF &PA NDS2005 or a Tie-Down per AC155 (*2 if paired)

3. System strength is limited to the lowest strength component in series. The example uses a bearing plate with an area of 20 sq in. on a dfl plate.

4. Evaluate elements for elongation (stretch). Stretch items include rod, tie-downs, holdowns, bearing plates, shrinkage compensators, and shrinkage. Elongation (Stretch) is adjusted based on the actual/maximum load, with one important exception. The full value of “ Δ_R , average travel and seating increment” must be used **without** adjustment. This movement is independent of load and is added to system stretch **in full**.

5. Adjust components to meet elongation requirements. Increase: rod size, bearing plates, tie-down size etc., as needed to meet required elongation.

6. Evaluate shrinkage compensators for acceptable expansion capacity. Shrinkage is cumulative.

Systems Compared

To help understand the process a single floor is evaluated and the systems compared. Example System Requirements: **Strength** = 11,000 pounds, **Elongation**: rod = 0.125” (required limit), system = 0.179” Limit, **Shrinkage** = 1”, Floor height 10’. Components evaluated for strength and elongation include rod, bearing plates and shrinkage compensator (take-up or Tud)

Table 3: System Design Examples

Component			Rod+Screw Tud		Tie-Downs		Rod+Ratchet Tud			
			Strength	Δ	Strength	Δ	Strength	Δ		
1	Rod	A36 (A307)	Gross or Net Area	13,530	0.092	13,530	0.018	13,510	0.092	
2	Plate	(OR)	AF&PA	Bearing @ 625 psi (Plate 3-1/4" X 6")	12,360	0.036	Not Used	12,360	0.036	
	Tie-Down		AC155	Tested Component	Not Used		11,810	0.244	Not Used	
3	Shrinkage (and/or) Tud	Calculated	Design Calc. Per ?			0.000		0.250	0.000	
			AC316	Per Sec 6.0.1 Allowable Load		25,300		Not Used		32,670
				Sec. 6.0.5 Elongation @ load.			0.014			0.031
				Sec. 6.0.6 Δ _R , Avg travel Increment			0.002			0.111
Strength Limit	Limit (Per Requirements)			11,000		11,000		11,000		
Limit	Demand/Capacity Ratio (per limiting component)			89%		93%		89%		
Elongation Limit	Calculated (Δ _a): Sum of Rod, Plate and Tud				0.143		0.512		0.269	
	System Demand /Capacity Ratio				80%		286%		150%	

Component #1. Rod Rod properties are calculated per IBC 2009, AISC 360. The rated strength for the specified rod is evaluated first. In the example, 7/8” dia. (A36/A307) rod is load rated at 13,530 pounds. At rated capacity a 10’ length will supply 0.113 inch elongation. Adjusting the elongation for the required strength (11,000 lbs.) gives rod stretch of 0.092”. (Note: using pre-calculated stretch for a 10’ rod length makes it easier for the designer to quickly gauge system stretch). Rod strength and stretch information is supplied by the manufacturer. Stretch may be determined using: $\Delta l = Pl_R/A_e E^{13}$.

Component #2. Bearing Plate or Tie-Down Tie-down loads are distributed into the structure through a bearing plate or tie-down. Tie-down strength and elongation are rated using AC155. Two common problems are routinely noted with AC155 numbers. Supplied numbers may be from an older, out-of-date code and when used across a floor system and two tie-downs are used, the elongation numbers **must be doubled**.

The example uses a bearing plate with dimensions of 5/8” x 3-1/4” x 6”. On Douglas Fir-Larch (625 psi. allowable) the capacity is 12,360 pounds. The deflection assigned to wood bearing is 0.040” at maximum allowable load. The design load deflection (11 kips) is 0.036”.

Component #3. Shrinkage and/or Shrinkage Compensator. The shrinkage evaluation may result in three possible outcomes: a. Shrinkage is non-existent or low and is included as part of system elongation. (common with a single-story slab-on-grade connection). b. Shrinkage is significant (1/8” or more) but is not addressed (most common), or. Shrinkage is significant and is addressed through the use of a shrinkage compensating device.

The example uses shrinkage of 1/4”. To compensate for shrinkage/settling a proprietary device is used. This code rated product, fits either 7/8” or 1” rod, accommodates 1.1” of shrinkage, has an assigned design load of 25,300 pounds with a rated design load deflection of 0.032” and has a tested movement (Δ_r, **Average travel and seating increment**) of 0.002”.

Some devices may have a “Δ_R, average travel and seating increment”, as great as 0.180”. This number must be supplied based on testing per ICC ES AC 316¹⁴. If the supplier can’t supply this information, rod thread pitch is a good starting point. Use the thread pitch of the rod being used. For example, with a thread pitch of 11 tpi (5/8”-11 thread) the Δ_r is 0.091¹⁵. With a thread pitch of 9 tpi (7/8”-9 thread) the backlash is 0.111”. The strength and stretch of nuts, couplers and

washers are not included in this analysis. Couplers, nuts and washers are specified to be grade compatible to the specified rod. Coupler, nut and washer stretch is not added.

Graph #1: “Understanding System Load-Deflection” is the key to understanding complete systems. **Bracket Tie-Downs** are shown in two places. The first uses a zero offset (no shrinkage) start point to begin the load deflection curve. Even with zero shrinkage the bracket pair introduces sufficient deflection to exceed the system elongation limit (0.179”) at about 7,000 pounds. With shrinkage of just ¼” the starting point begins at ¼” and system deflection exceeds ½”. **Ratchet tie-downs** always have some internal looseness because of the Δ_r . In this case the Δ_r adds 0.111” of intrinsic internal ratchet looseness. The **screw device** adds 0.002 Δ_r , with total deflection of 0.143” Note: this is in addition to the load-deflection deformation.

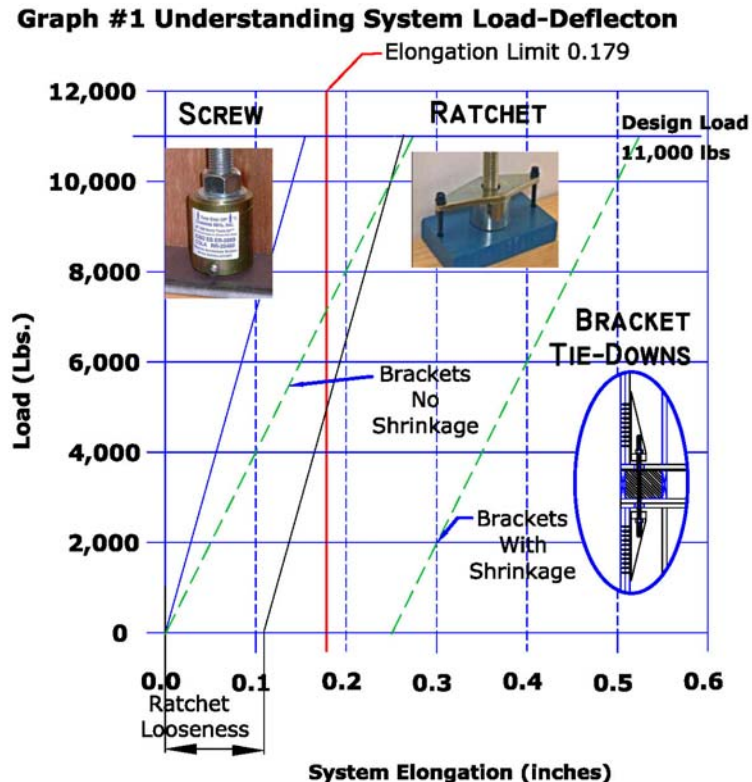

Summary

If shear walls are to perform at their rated loads, system elongation must be limited. In the example the best system has a **rod** elongation of 0.092”, while **system** elongation is 0.142”. If lower system stretch is required, rod diameter or plate area may be increased. With so many interconnected variables proper design is complicated.

System design made easy.

You may have come to the conclusion that fast and accurate designs are difficult. They are. Several companies offer automatic calculation packages that allow the design of a complete system in minutes. Some systems allow you to adjust tension rod or bearing plates with an instant feed back on system elongation. These design systems also link to complete, ready to review calculation packages. One caution however: verify that all components and properties are

included under the latest ICC ES revisions, dated July 1, 2010, the changes are **VERY** significant. Many systems don't list Δ_r . If Δ_r is missing, the system needs a closer look.

The Author

Alfred Commins has been designing structural connectors for 35 years. He currently has more than 40 U.S. and Foreign patents in the connector and other industries. He is the President of Commins Manufacturing Inc. Commins Manufacturing makes and sells the AutoTight Tie-Down System.

Please e-mail with comments, questions or suggestions. al@comminsmfg.com

Side Bar: Why the Focus on System Elongation?

Several protocols have been used over the last 50 years to test and rate shear resisting panels. ASTM E72 was among the earliest test procedures. It tested a pair of shear panels nailed to framing members. Tie downs consisted of a pair of 1-1/4" steel rods with rollers on the top of the wall to preventing uplift. This is a great source of accurate data on the lateral performance of shear panels but it doesn't address the effects of looseness. Over the years several other tests procedures were adopted until the latest AC 130 that tested systems in a cyclic manner.

In 2001 the City of Los Angeles tested a series of shear walls to the ICBO, Acceptance Criteria, AC130. AC 130 is a phased displacement cyclic test protocol. Tight systems performed well. A few tests covered loose shear walls with an induced looseness of 0.200". The result, a 40% reduction in the lateral capacity of the tested panels.

Section 2305.3 of the IBC requires the limiting of shear wall drift. Manufactured wood products and kiln dried wood has greatly reduced looseness but some looseness always remains. Properly designed tie-down systems, that include shrinkage compensators, can solve the loose shear wall problem and allow shear walls to perform at their full potential.

¹ **2009 International Building Code**, (IBC) International Code Council

² **AC155 Acceptance Criteria for Hold-Downs (Tie-Downs) Attached to Wood Members** July 1, 2010, ICC Evaluation Service, Whittier California

³ **AC 316, Acceptance Criteria For Shrinkage Compensating Devices**, July 1, 2010, ICC Evaluation Service, Whittier, California

⁴ **AC391 Acceptance Criteria for Continuous Rod Tie-Down Runs and Continuous Rod Tie-Down Systems Used to Resist Wind Uplift**, July 1, 2010, ICC Evaluation Service, Whittier California

⁵ **AC391 Acceptance Criteria for Continuous Rod Tie-Down Runs and Continuous Rod Tie-Down Systems Used to Resist Wind Uplift**, July 1, 2010, ICC Evaluation Service, Whittier California

⁶ **IBC 2009** Section 2305.3

⁷ **Shear Wall Continuous Tie-Down Systems**, Number 12 ICC Tri-Chapter Uniform Code Committee March 12, 2009

⁸ **AC391 Acceptance Criteria for Continuous Rod Tie-Down Runs and Continuous Rod Tie-Down Systems Used to Resist Wind Uplift**, July 1, 2010, Section 3.2.1.1

⁹ Area shown is for continuous rod per AC391 3.2.1.1. For full diameter rod Area $A = \pi \cdot (D^2/4)$

¹⁰ Ibid, Section 3.2.1.2.

¹¹ Ibid, Section 3.1.1 and AC 155, July 1, 2010, section 6.2.6.3

¹² **AC391 Acceptance Criteria for Continuous Rod Tie-Down Runs and Continuous Rod Tie-Down Systems Used to Resist Wind Uplift**, July 1, 2010, Section 3.1.1. ICC Evaluation Service, Whittier CA,

¹³ Ibid 8.

¹⁴ **AC391**, Section 3.1.1

¹⁵ **Rod pitch** is a good starting point for Δ_R “average travel and seating increment”. Consider that the nut must engage the full thread depth for full strength. Partial engagements will reduce bearing and capacity, which is why I suggest using the full thread pitch. In addition to pitch, devices have looseness because they consist of moving parts. Up to 1/8” or more of looseness can be demonstrated in moving ratchets before they jump a thread. . This then takes us to averages. The average ratchet can be 0100” but it could vary from 0.050 to 0.200”. I suggest the official number be requested from the ICC ES report.